



Installation instructions

email850P

email800

email350

Content

1. General	Page 4
2. Transport and storage	Page 5
3. Installation	Page 6-9
3.1. Before installation	Page 6
3.2. Installation procedure	Page 6
3.3. Fitting of flange connections	Page 7
3.4. Gaskets	Page 7
3.5. Selection and installation of supports	Page 8-9
4. Earthing of glass lined pipe work	Page 10
5. Leakage test	Page 11
6. Connections	Page 12-13
6.1. Bolt tightening torques	Page 12-13
6.2. Bolt dimensions for flange connections (DIN/ANSI)	Page 14-15
6.2.1. Reducing flange with studs	Page 16
6.2.2. Reducing flange with hexagon bolts	Page 17
6.2.3. Dimensions for stud bolts with spacers to DIN PN 10 and ANSI 150	Page 18-19
7. Flange connections to DIN 2501 PN 10 /16/ 25 and ANSI 150 / 300 lbs.	Page 20-21
8. Thermal expansion of glass lined pipes	Page 22
9. Admissible bending	Page 23

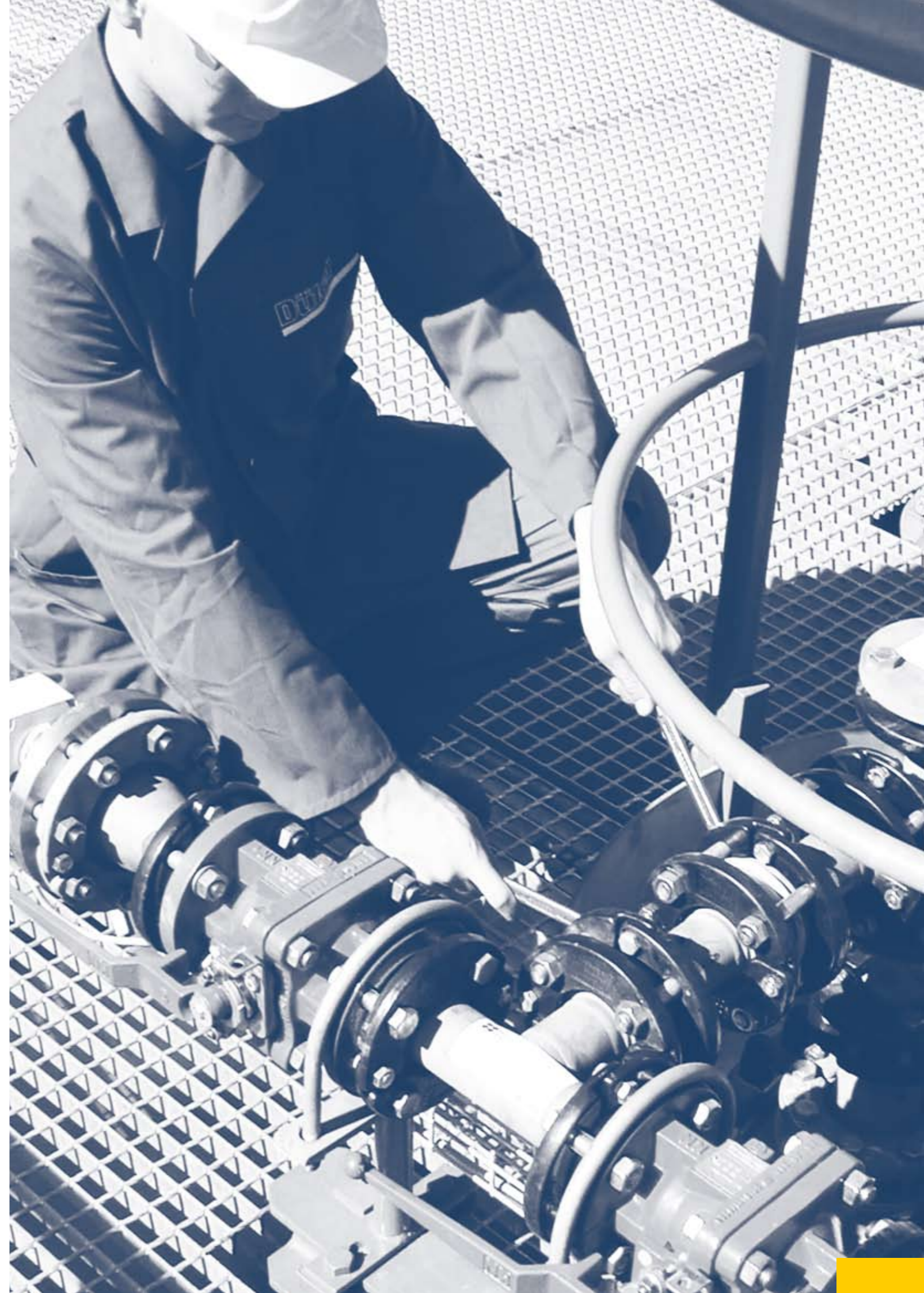

1. General

Glass lined steel pipe parts are robust in application. They can be used in many and varied applications and are a sure investment but demand careful handling in transport and installation. This is why we would like to give you some instructions and make suggestions as to how to handle glass lined steel pipework. The contained information refers to **email800** as well as for the other enamel qualities such as **email350** and **email850P**.



2. Transport and storage

As a standard these pipe parts are delivered to you with protective caps in strong wooden crates. Please check all the parts for any possible damage incurred during transport and immediately report such damage to Düker. It is best to leave the parts in the transport packaging for intermediate storage. Should this be not possible ensure careful storage on wood pallets, for example, or similar surface and make sure:



- that the parts are safeguarded against rolling or sliding off



- to avoid external loads

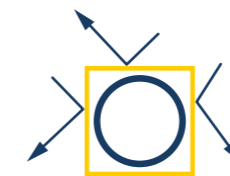

- to avoid vibration and impact

- to prevent the external and g / l surfaces from being scratched

Do NOT remove the protective caps from the pipeline parts!



3. Installation

3.1. Before installation

- Ensure that the parts with the fitted protective caps are not subject to impact during transportation to the installation site.
- Take measures to prevent the pipelines being damaged by other contractors working on the site (when scaffolding is being erected, etc.).
- Do not place unprotected glass lined parts with their glass surfaces on the ground or on gratings.

3.2. Installation procedure



As a matter of principle glass lined pipelines must be installed without stress and must not be subjected to external loads!

- The line is to be laid from a connection point (tank, pump, nozzle etc.).
- The pipe parts are to be set up at the right height and be held temporarily in position (using suspension fasteners, mounts, anchors, etc.).
- Freely suspended pipeline parts are to be avoided.
- Now fit and close the flanges (cf. section 3.3). Make sure that the sealing surfaces are parallel and flat.
- If necessary fit supports (cf. section 3.5).
- Note falls and changes in length due to thermal expansion (cf. section 6.4 + 6.5).
- Create falls by means of angle spacers or by turning the elbows.
- Finally, align pipeline and tighten bolting.
- Continue similarly with further pipeline elements.
- Spacers are to be used in the pipeline to adjust to the required length.



In no event are the lines to be subject to tension through compression or stretching.

3.3. Fitting of flange connections

- Fit the two halves of the loose flange on one side with a flange connection bolt.
- Offset the flange and counter flange joints by 90°.
- Hinge the connected halves and place them around the stub ends with the recessed end of the flange (centring) towards the collar.
- Tighten the bolts crosswise alternately and consistently until the recommended torque is reached (cf. section 6.1).
- Close the connected halves and bolt together.
- We recommend the use of studbolts for connecting the spacers, angle spacers and instrument tees (cf. section 6.2.4).
- Proceed in the same way and fit the counter flange.

3.4. Dichtungen

Gaskets For connecting the glass lined steel pipes Düker recommends gaskets comprising corrugated stainless steel ring with a soft layer on both sides and PTFE envelope as well as gaskets of modified PTFE. Selection and application depends on the applied strain and stress and the properties of the gaskets must be agreed between the gasket manufacturer and the user. The range of gaskets that have been tested in practice can be seen in the following table:

Type	Structure	Thickness not-compressed/compressed mm	Temperature/ application area °C
1	PTFE envelope graphite gasket	4,0 / 3,0	- 50 / + 230
1	from DN 250 with corrugated steel ring and graphite layers on both sides	6,5 / 5,0	- 50 / + 230
2	PTFE envelope gasket with corrugated steel ring and aramid layers on both sides	6,5 / 5,0	- 50 / + 150
3	Gylon blue (3504E)	3,2 / 2,0	- 210 / + 260
4	IDT-Unifluor (WS 7550)	3,2 / 2,0	- 210 / + 260
5	Gore Style 800	6,0 / 2,0	- 240 / + 270

- Ensure centring of the gasket between the stub ends of the pipes
- Gaskets that have been fitted once must not be reused!

3. Installation

3.5. Selection and installation of supports

Examples of specific support systems used for glass lined pipelines:

→ flexible; → fixed

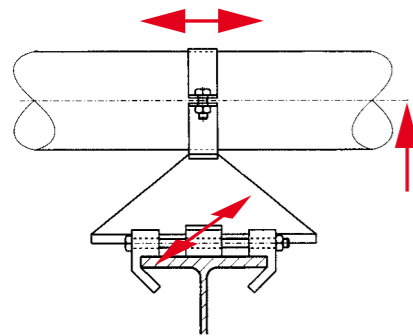

Fig. 1 fixed support

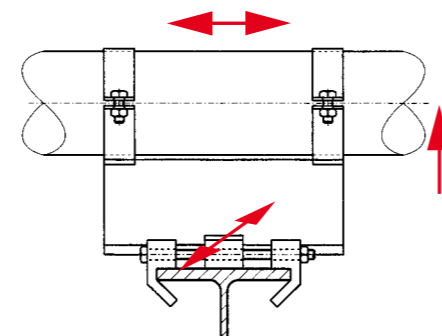

Fig. 2 fixed support with two rings

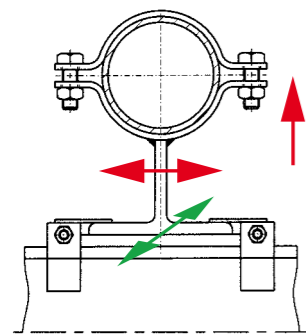

Fig. 3 guiding support

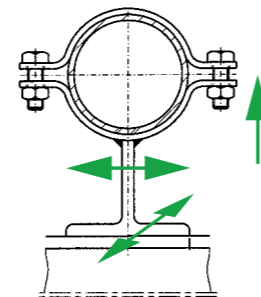

Fig. 4 loose support

As a matter of principle the types of supports and distances listed in the isometric shall be adhered to. However, the following maximum distances between the supports are applicable:

DN	Distance mm
25 - 100	3000
125 - 300	4000



To be considered when laying and positioning the supports:

- The different pipe sections must have a fixed point to ensure controlled expansion of the pipelines.
- Rising lines are to be fixed by means of fixed points so that the horizontal systems below or above these points are not subject to any additional cross forces due to their weight.
- Apparatus and pumps are considered fixed points.
- Compensators must be given a fixed point on one end and a guiding or loose support on the other end.
- Heavy fittings are to be supported separately.
- All types of supports are to be fitted to prevent any stress being transferred to the installed pipeline.
- Pipe rings on all three types of holders are to be done up tight and fibre glass textile band of about 1 mm is to be placed between the pipe rings and pipe body.
- Pipeline movement through thermal expansion will be compensated by means of a sliding support shoe on the guiding and loose bearing.
- U-type supports (Fig. 5) must not be used on glass lined pipelines because, when tightened, these damage the glass lining (Exception: U-type guiding supports, cf. Figure 6).



Important note:
NO welding work is to be undertaken on glass lined pipes!

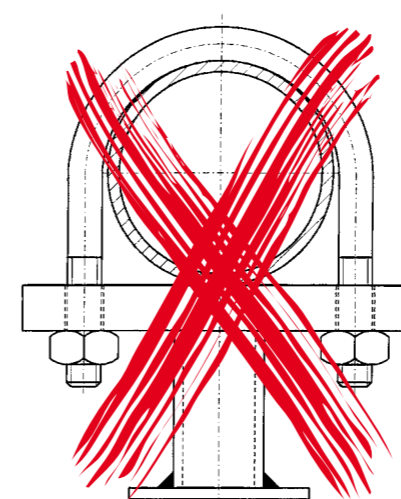

Fig. 5 U-type support

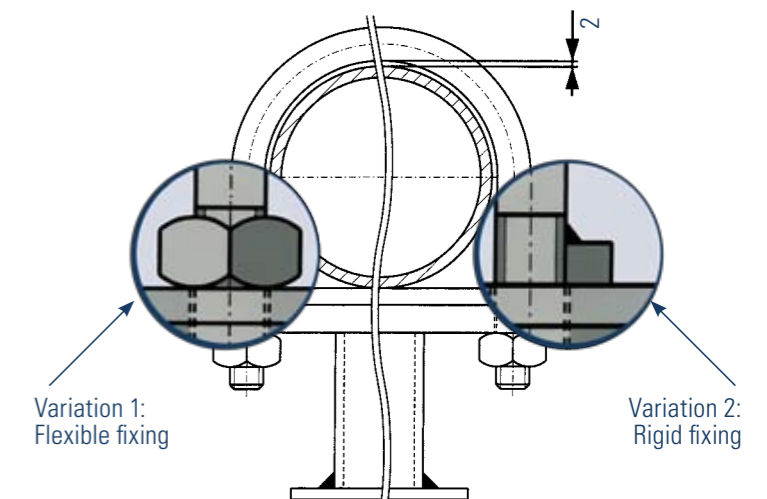

Fig. 6 U-type guiding support

4. Earthing of glass lined pipework

To discharge electrostatic charges through glass lined pipe systems, such systems must be earthed, either by earthing studs or by galvanisation of the external surface of the pipework.

Earthing by studs

- The pipeline parts (depending upon construction length) are provided with 1 or 2 earthing studs.
- The studs are to be connected with the fastening bolts of the loose flanges by an earthing wire.
- Bellows of non-conductive material are to be bridged by a wire.
- Düker also offers gaskets with earthing studs. Upon installation these studs are to be connected with the flange bolts.

Earthing by external galvanization

- The galvanisation replaces the external corrosion paint and the earthing wires.
- Flangeless components such as spacers, angle spacers or instrument tees must be equipped with earthing studs in all cases.

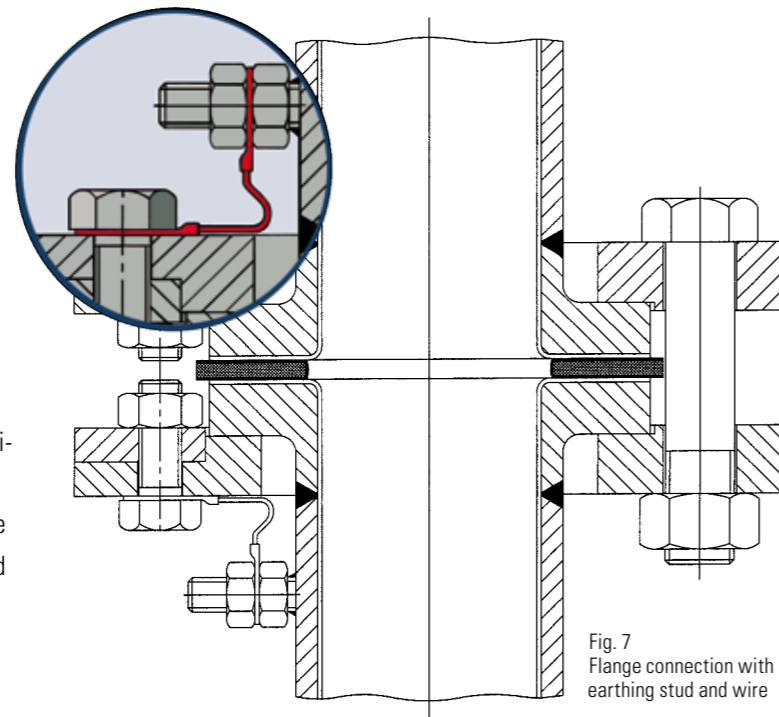

5. Leakage test

All pipeline parts from Düker comply with the regulations of the EC pressure equipment directive (PED).

The pressure testing of the installed glass lined pipeline is to be carried out with liquid (water) or with gas (air or nitrogen) at 1,1 times of the admissible working pressure. When testing with gas make sure you take special safety measures (AD-2000-“Merkblatt” HP 30).

Our pipework is subject to a non-destructive test to AD-2000, HP 100 R, “Tafel 3” and to a high tension test with 20 000 V after glassing.

6. Schraubverbindungen

6.1. Bolt tightening torques

The connection bolts are to be fastened with a torque wrench consistently crosswise and then repeatedly until the required torque is reached.

Torques in Nm for DIN connections

DN mm	Bolts Number x size	Gylon blue	PTFE envelope gasket with corrugated steel ring and aramid layers on both sides	PTFE envelope graphite gasket*	Gore S 800
25	4 x M 12	20	20	15	30
32	4 x M 16	35	35	25	50
40	4 x M 16	40	40	30	60
50	4 x M 16	60	60	45	80
65	4 x M 16	80	80	65	90
80	8 x M 16	55	55	45	65
100	8 x M 16	65	65	50	70
125	8 x M 16	80	80	65	90
150	8 x M 20	120	120	90	120
200	8 x M 20	160	160	120	170
250	12 x M 20	135	135	110	130
300	12 x M 20	160	160	135	150

* from DN 250 with graphite layers on both sides

Torques in Nm for ANSI connections

DN Inch	Bolts Number x size	Gylon blue	PTFE envelope gasket with corrugated steel ring and aramid layers on both sides	PTFE envelope graphite gasket*	Gore S 800
1	4 x M 12	15	15	12	20
1 ¼	4 x M 12	20	20	15	35
1 ½	4 x M 12	30	30	25	45
2	4 x M 16	60	60	45	80
2 ½	4 x M 16	70	70	55	85
3	4 x M 16	80	80	60	90
4	8 x M 16	65	65	50	70
5	8 x M 20	100	100	75	110
6	8 x M 20	120	120	90	120
8	8 x M 20	160	160	120	170
10	12 x M 20	145	145	110	140
12	12 x M 20	175	175	135	150

* from DN 250 with graphite layers on both sides

We recommend to re-tighten the bolts at ambient temperature after the first temperature cycle. In case of any leakage retighten the bolts. You may exceed the given torques by 30%.



Basis for the application of tightening torques are greased bolts in the threaded and supporting area of the bolts.

6.2. Bolt dimensions

for flange connections

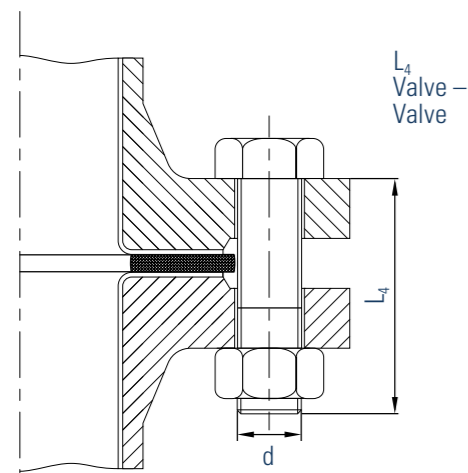
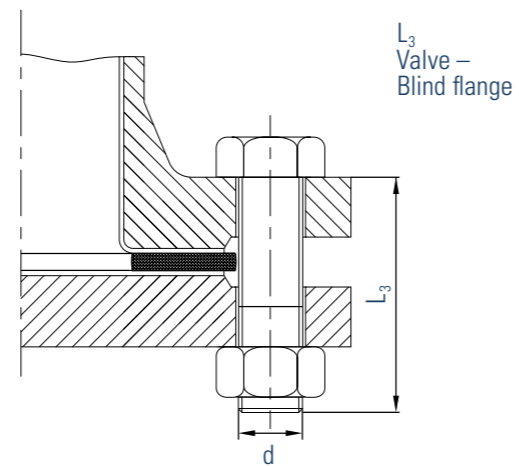
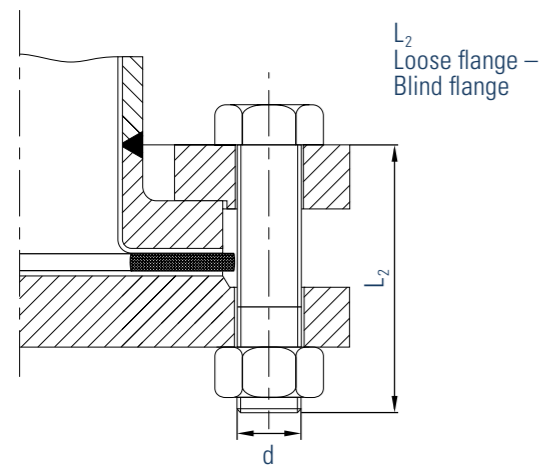
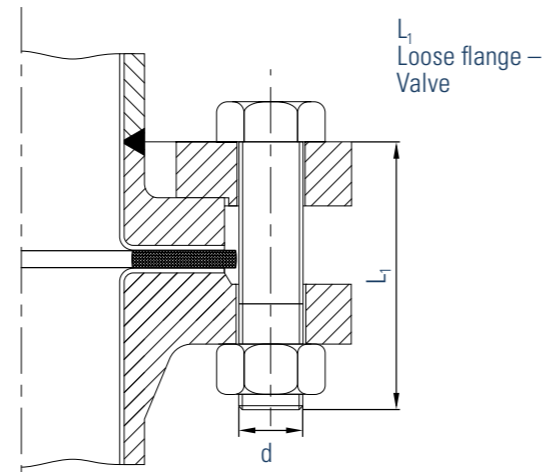
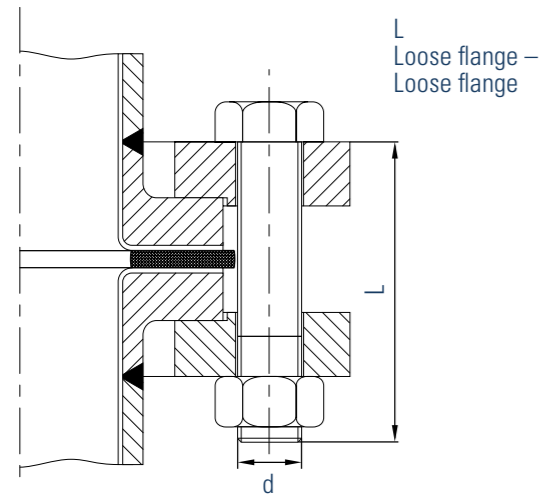

Bolt dimensions for flange connections (DIN PN 10)

mm	inch	Thread d	Number	L mm	L_1 mm	L_2 mm	L_3 mm	L_4 mm
25	1	M 12	4	70	60	60	55	55
32	1 ¼	M 16	4	75	65	65	60	60
40	1 ½	M 16	4	75	65	65	60	60
50	2	M 16	4	80	70	70	60	60
65	2 ½	M 16	4	85	75	75	60	60
80	3	M 16	8	90	80	80	65	65
100	4	M 16	8	95	80	80	65	65
125	5	M 16	8	100	85	85	70	70
150	6	M 20	8	110	90	90	75	75
200	8	M 20	8	120	100	100	75	75
250	10	M 20	12	130	110	110	80	80
300	12	M 20	12	140	110	110	85	85

Bolt dimensions for flange connections (ANSI 150)

mm	inch	Thread d	Number	L mm	L_1 mm	L_2 mm	L_3 mm	L_4 mm
25	1	M 12	4	70	60	60	50	50
32	1 ¼	M 12	4	75	65	65	55	55
40	1 ½	M 12	4	70	65	65	55	55
50	2	M 16	4	80	70	70	65	65
65	2 ½	M 16	4	90	80	80	70	70
80	3	M 16	4	90	80	80	75	75
100	4	M 16	8	95	85	85	75	75
125	5	M 20	8	110	90	90	75	75
150	6	M 20	8	110	95	95	80	80
200	8	M 20	8	120	100	100	85	85
250	10	M 20	12	130	100	100	90	90
300	12	M 20	12	140	110	110	90	90

6.2. Bolt dimensions

for flange connections

6.2.1.Reducing flange with studs

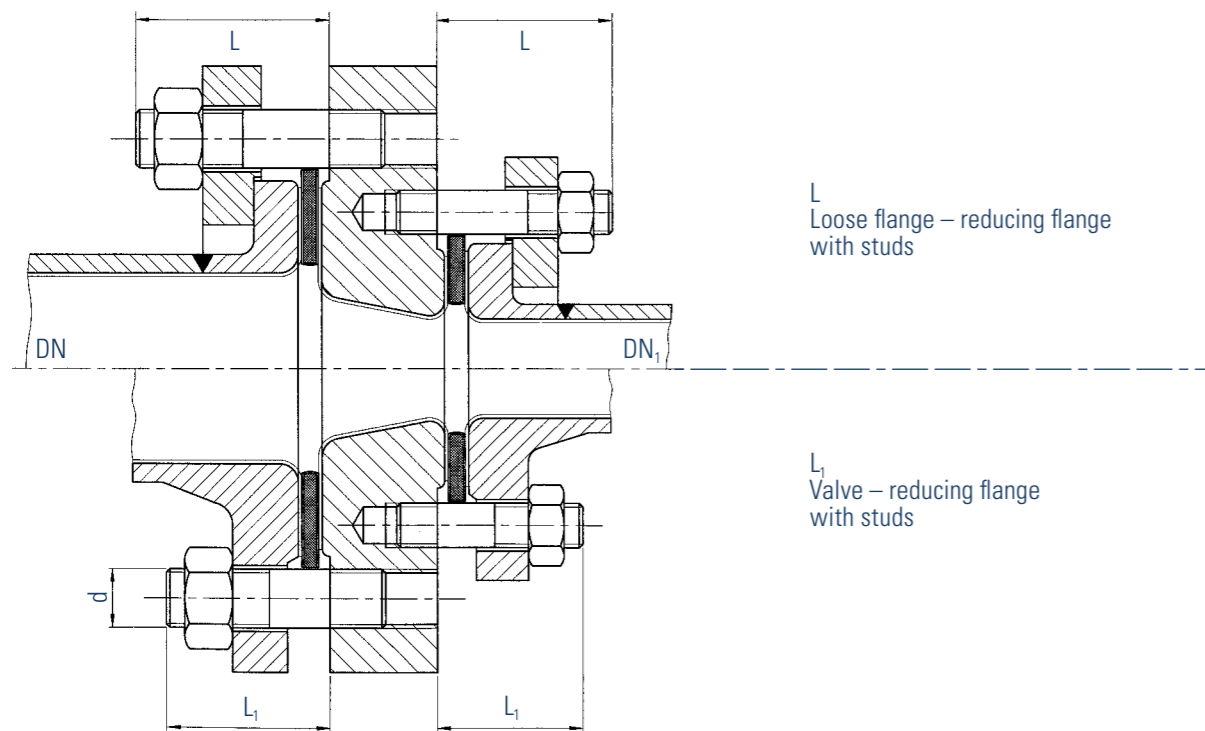

Bolt dimensions for flange connections with studs (DIN PN 10)

DN / DN ₁ mm	Thread d	Number	L mm	L ₁ mm
25	M 12	4	50	40
32	M 16	4	50	40
40	M 16	4	50	40
50	M 16	4	55	45
65	M 16	4	55	45
80	M 16	8	60	45
100	M 16	8	60	45
125	M 16	8	60	50
150	M 20	8	70	50
200	M 20	8	75	50
250	M 20	12	80	55
300	M 20	12	85	55

Bolt dimensions for flange connections with studs (ANSI 150)

DN / DN ₁ inch	Thread d	Number	L mm	L ₁ mm
1	M 12	4	50	35
1 ¼	M 12	4	50	40
1 ½	M 12	4	50	40
2	M 16	4	55	45
2 ½	M 16	4	55	45
3	M 16	4	60	50
4	M 16	8	60	50
5	M 20	8	70	50
6	M 20	8	70	50
8	M 20	8	75	55
10	M 20	12	80	55
12	M 20	12	85	60

6.2.2. Reducing flange with hexagon bolts

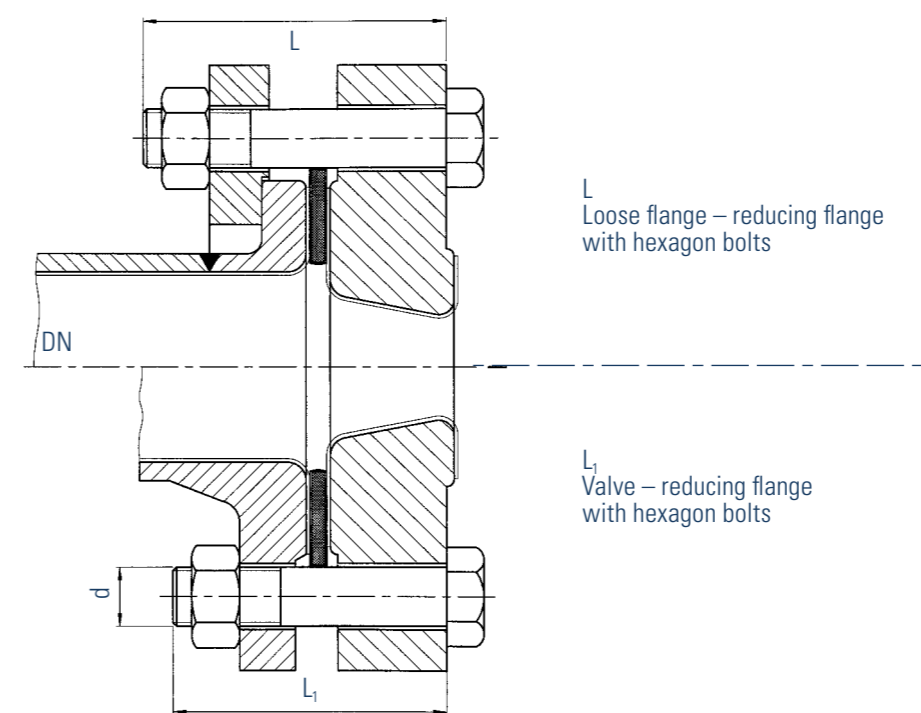

Bolt dimensions for flange connections with hexagon bolts (DIN PN 10)

DN mm	Thread d	Number	L mm	L ₁ mm
25	M 12	4	80	70
32	M 16	4	80	75
40	M 16	4	80	75
50	M 16	4	85	75
65	M 16	4	90	75
80	M 16	8	90	75
100	M 16	8	100	85
125	M 16	8	110	90
150	M 20	8	110	90
200	M 20	8	120	95
250	M 20	12	120	95
300	M 20	12	130	95

Bolt dimensions for flange connections with hexagon bolts (ANSI 150 lbs.)

DN inch	Thread d	Number	L mm	L ₁ mm
1	M 12	4	80	70
1 ¼	M 12	4	80	70
1 ½	M 12	4	80	70
2	M 16	4	85	75
2 ½	M 16	4	90	80
3	M 16	4	90	80
4	M 16	8	100	90
5	M 20	8	110	95
6	M 20	8	110	95
8	M 20	8	120	100
10	M 20	12	120	100
12	M 20	12	130	100

6.2. Bolt dimensions

for flange connections

6.2.3. Studbolts with spacers

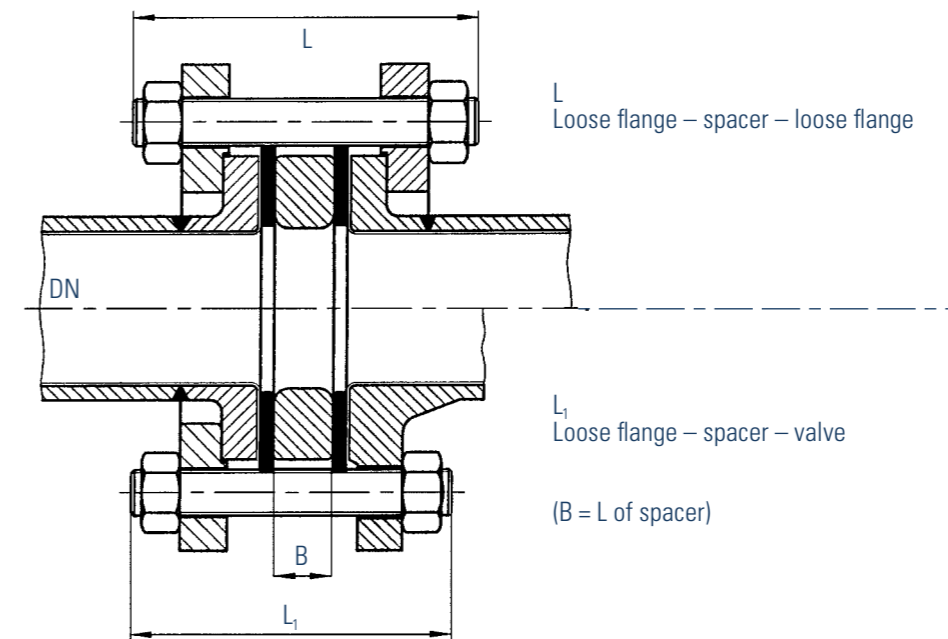
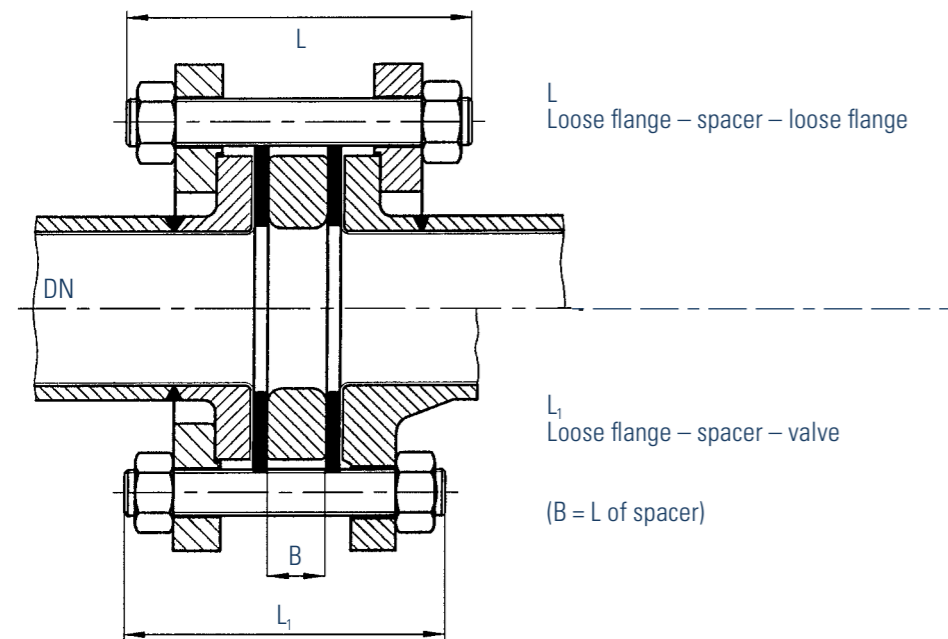

Dimensions for studbolts with spacers to DIN PN 10

DN mm	NB inch	Thread	Number	Spacer length in mm (B)													
				10 L/L ₁	15 L/L ₁	20 L/L ₁	25 L/L ₁	30 L/L ₁	35 L/L ₁	40 L/L ₁	45 L/L ₁	50 L/L ₁	60 L/L ₁	70 L/L ₁	80 L/L ₁	90 L/L ₁	100 L/L ₁
25	1	M 12	4	100/90	110/100	110/110	120/110	120/110	130/120	130/120	140/130	140/130	150/140	160/150	170/160	180/170	
32	1 ¼	M 16	4	110/100	110/100	120/110	120/110	130/120	130/120	140/130	140/130	150/140	160/150	170/160	180/170	190/180	
40	1 ½	M 16	4	110/100	110/100	120/110	120/110	130/120	130/120	140/130	140/130	150/140	160/150	170/160	180/170	190/180	
50	2	M 16	4	120/110	120/110	130/120	130/120	140/130	140/130	150/140	150/140	160/150	170/160	180/170	190/180	200/190	
65	2 ½	M 16	4	120/110	130/120	130/120	140/130	140/130	150/140	150/140	160/150	170/160	180/170	190/180	200/190	210/200	
80	3	M 16	8	130/120	130/120	140/130	140/130	150/140	150/140	160/150	160/150	170/160	180/170	190/180	200/190	210/200	
100	4	M 16	8	130/120	130/120	140/130	140/130	150/140	150/140	160/150	160/150	170/160	180/170	190/180	200/190	210/200	
125	5	M 16	8		140/130	150/140	150/140	160/150	160/150	170/160	180/170	190/180	200/190	210/200	220/210	230/220	240/230
150	6	M 20	8		150/140	160/150	160/150	170/160	170/160	180/170	180/170	190/180	200/190	210/200	220/210	230/220	240/230
200	8	M 20	8		160/150	170/160	170/160	180/170	180/170	190/180	190/180	200/190	210/200	220/210	230/220	240/230	250/240
250	10	M 20	12		170/160	180/170	180/170	190/180	190/180	200/190	200/190	210/200	220/210	230/220	240/230	250/240	260/250
300	12	M 20	12		180/170	180/170	190/180	190/180	200/190	200/190	210/200	210/200	220/210	230/220	240/230	250/240	260/250

Dimensions for studbolts with spacers to ANSI 150 lbs.

DN mm	NB inch	Thread	Number	Spacer length in mm (B)													
				10 L/L ₁	15 L/L ₁	20 L/L ₁	25 L/L ₁	30 L/L ₁	35 L/L ₁	40 L/L ₁	45 L/L ₁	50 L/L ₁	60 L/L ₁	70 L/L ₁	80 L/L ₁	90 L/L ₁	100 L/L ₁
25	1	M 12	4	100/90	110/100	110/110	120/110	120/110	130/120	130/120	140/130	140/130	150/140	160/150	170/160	180/170	
32	1 ¼	M 12	4	110/100	110/100	120/110	120/110	130/120	130/120	140/130	140/130	150/140	160/150	170/160	180/170	190/180	
40	1 ½	M 12	4	100/90	110/100	110/100	120/110	120/110	130/120	130/120	140/130	140/130	150/140	160/150	170/160	180/170	
50	2	M 16	4	120/110	120/110	130/120	130/120	140/130	140/130	150/140	150/140	160/150	170/160	180/170	190/180	200/190	
65	2 ½	M 16	4	130/120	130/120	140/130	140/130	150/140	150/140	160/150	160/150	170/160	180/170	190/180	200/190	210/200	
80	3	M 16	4	130/120	130/120	140/130	140/130	150/140	150/140	160/150	160/150	170/160	180/170	190/180	200/190	210/200	
100	4	M 16	8	130/120	130/120	140/130	140/130	150/140	150/140	160/150	160/150	170/160	180/170	190/180	200/190	210/200	
125	5	M 20	8		150/140	150/140	160/150	160/150	170/160	170/160	180/170	180/170	190/180	200/190	210/200	220/210	230/220
150	6	M 20	8		150/140	150/140	160/150	160/150	170/160	170/160	180/170	180/170	190/180	200/190	210/200	220/210	230/220
200	8	M 20	8		160/150	170/160	170/160	180/170	180/170	190/180	190/180	200/190	210/200	220/210	230/220	240/230	250/240
250	10	M 20	12		170/160	170/160	180/170	180/170	190/180	190/180	200/190	200/190	210/200	220/210	230/220	240/230	250/240
300	12	M 20	12		180/170	180/170	190/180	190/180	200/190	200/190	210/200	210/200	220/210	230/220	240/230	250/240	260/250

7. Flange dimensions

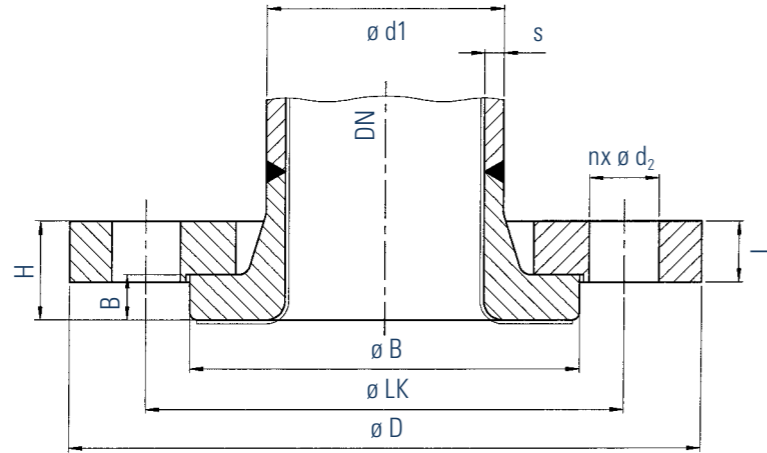

Flange dimensions to DIN 2501 PN 10 / 16 / 25

DN	ø D PN			ø LK PN			ø B PN			nx ø d ₂ PN			Pipe dim. ø d ₁ xs	Flange thickness PN 10			
	mm	inch	10	16	25	10	16	25	10	16	25	10		16	25	H	B
15	½	95	95	95	65	65	65	45	45	45	4 x 14	4 x 14	4 x 14	22 x 3,5	20	10	12
20	¾	105	105	105	75	75	75	58	58	58	4 x 14	4 x 14	4 x 14	30 x 4	20	10	12
25	1	115	115	115	85	85	85	68	68	68	4 x 14	4 x 14	4 x 14	35 x 4	24	12	14
32	1 ¼	140	140	140	100	100	100	78	78	78	4 x 18	4 x 18	4 x 18	42 x 4	24	12	14
40	1 ½	150	150	150	110	110	110	88	88	88	4 x 18	4 x 18	4 x 18	50 x 4	24	12	14
50	2	165	165	165	125	125	125	102	102	102	4 x 18	4 x 18	4 x 18	62 x 5	28	14	16
65	2 ½	185	185	185	145	145	145	122	122	122	4 x 18	4 x 18	8 x 18	75 x 5	30	14	18
80	3	200	200	200	160	160	160	138	138	138	8 x 18	8 x 18	8 x 18	90 x 5	32	16	18
100	4	220	220	235	180	180	190	158	158	162	8 x 18	8 x 18	8 x 23	110 x 5	34	16	20
125	5	250	250	270	210	210	220	188	188	188	8 x 18	8 x 18	8 x 27	135 x 5	37	18	22
150	6	285	285	300	240	240	250	212	212	218	8 x 23	8 x 23	8 x 27	160 x 5	39	18	24
200	8	340	340	360	295	295	310	268	268	278	8 x 23	12 x 23	12 x 27	220 x 8	45	20	28
250	10	395	405	425	350	355	370	320	320	335	12 x 23	12 x 27	12 x 30	271 x 9	51	22	32
300	12	445	460	485	400	410	430	370	370	395	12 x 23	12 x 27	16 x 30	322 x 9	53	22	34
350	14	505	520	555	460	470	490	430	430	450	16 x 23	16 x 27	16 x 33	355 x 8	60	25	35
400	16	565	580	620	515	525	550	482	482	505	16 x 27	16 x 30	16 x 36	406 x 10	68	28	40
450	18	615	640	-	565	585	-	532	532	-	20 x 27	20 x 30	-	457 x 10	70	30	40
500	20	670	715	730	620	650	660	585	585	515	20 x 27	20 x 33	20 x 36	508 x 11	75	30	45

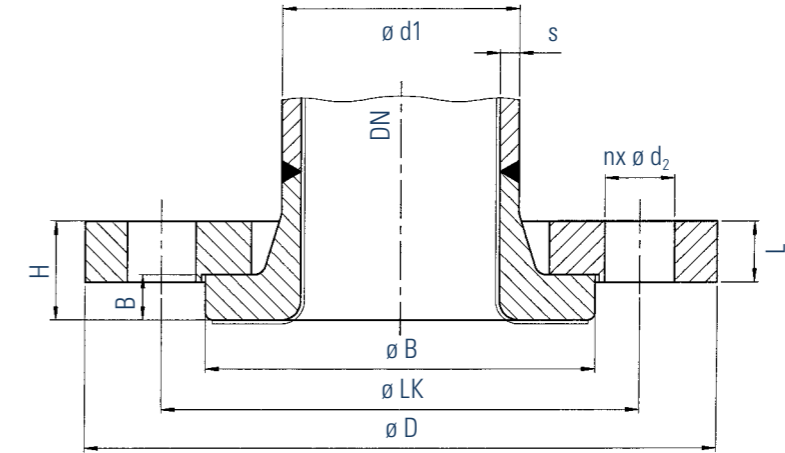

Flange dimensions to ANSI 150 / 300 lbs.

DN	ø D ANSI		ø LK ANSI		ø B ANSI		nx ø d ₂ ANSI		Pipe dim. ø d ₁ xs	Flange thickness ANSI			
	mm	inch	150	300	150	300	150	300		150	300	H	B
15	½	89	95	60	67	45	45	4 x 15	4 x 15	22 x 3,5	20	10	12
20	¾	98	116	70	83	53	53	4 x 15	4 x 19	30 x 4	20	10	12
25	1	108	124	79,5	89	61	61	4 x 15	4 x 19	35 x 4	24	12	14
32	1 ¼	117	133	89	98	71	71	4 x 15	4 x 19	42 x 4	28	12	16
40	1 ½	127	156	98,5	114	80	80	4 x 15	4 x 19	50 x 4	24	12	14
50	2	152	165	121	127	102	102	4 x 19	8 x 19	62 x 5	28	14	16
65	2 ½	178	191	140	149	118	118	4 x 19	8 x 23	75 x 5	34	14	18
80	3	191	210	152	168	130	130	4 x 19	8 x 23	90 x 5	32	16	18
100	4	229	254	191	200	158	158	8 x 19	8 x 23	110 x 5	34	16	20
125	5	254	279	216	235	188	188	8 x 23	8 x 23	135 x 5	38	18	20
150	6	279	318	241	270	212	212	8 x 23	12 x 23	160 x 5	38	18	23
200	8	343	381	298	330	268	268	8 x 23	12 x 25	220 x 8	43	20	26
250	10	406	445	362	387	320	320	12 x 25	16 x 28	271 x 9	47	22	25
300	12	483	521	432	451	370	370	12 x 25	16 x 31	322 x 9	52	22	30
350	14	533	584	476	514	430	430	12 x 28	20 x 31	355 x 8	60	25	35
400	16	597	648	540	572	482	482	16 x 28	20 x 36	406 x 10	68	28	40
450	18	635	711	578	629	532	532	16 x 31	24 x 36	457 x 10	70	30	40
500	20	698	775	635	686	585	585	20 x 31	24 x 36	508 x 11	75	30	45

8. Length increase due to thermal expansion of glass lined pipes

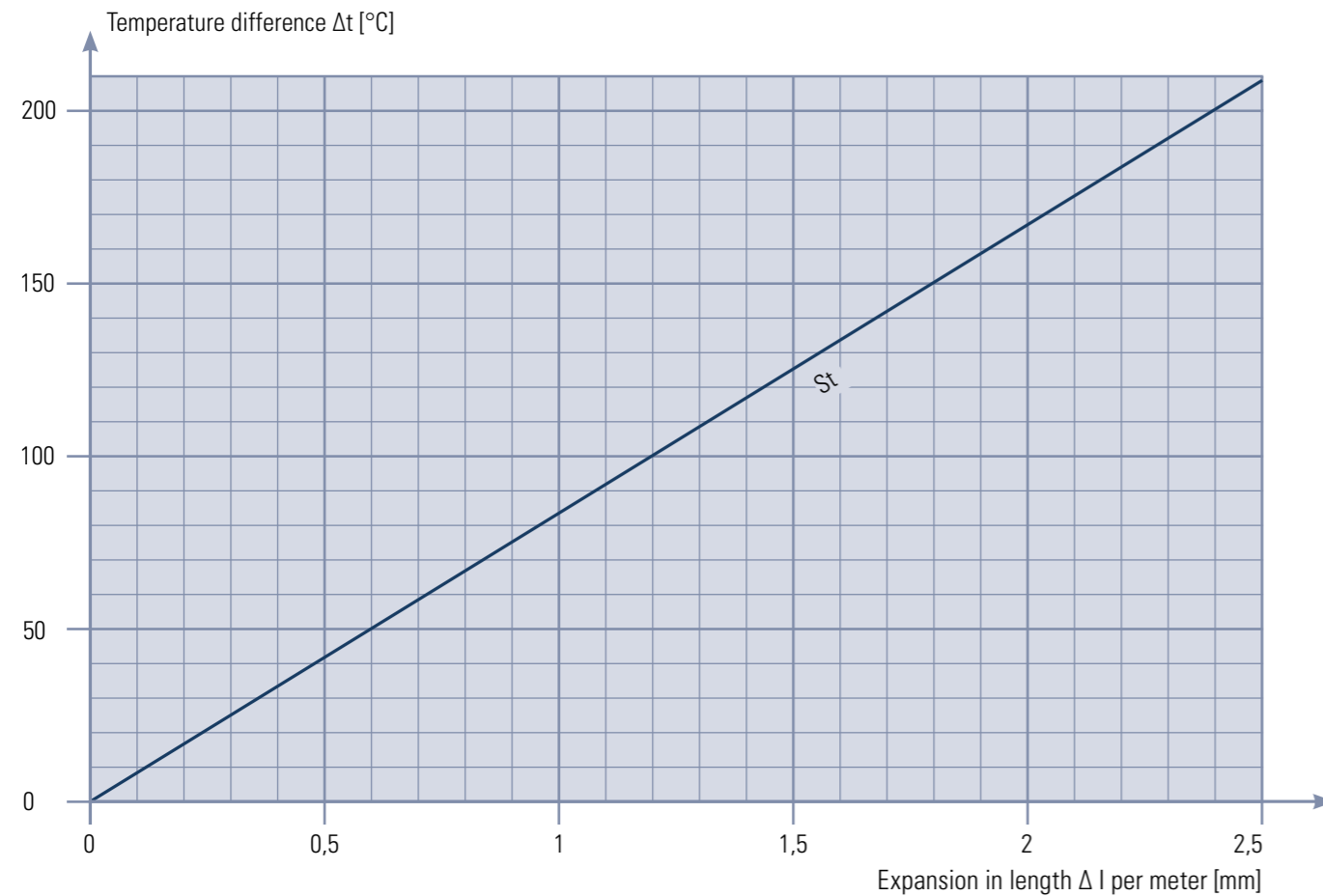

A change in temperature always causes a change in pipe length: $\Delta t = t_2 - t_1$ [°C]

The expansion in length is calculated by the following formula: $\Delta l = (t_2 - t_1) \cdot \alpha \cdot L$ [mm]

- L = Length of pipeline [m]
- Δl = Length of expansion [mm]
- t_1 = Lowest temperature [°C]
- t_2 = Highest temperature [°C]
- Δt = Temperature difference [°C]

$$\alpha St = 12 \cdot 10^{-3} \left[\frac{\text{mm}}{\text{m} \cdot ^\circ\text{C}} \right]$$

To be considered in the case of pipelines to be installed outdoors when determining t_1 and t_2 are the strong fluctuations in outdoor temperatures and irradiation of the sun.

The expansion in length (Δl) can be compensated by bellows or angle locking pipe legs of the appropriate length (L_1).

9. Admissible bending of glass lined pipes

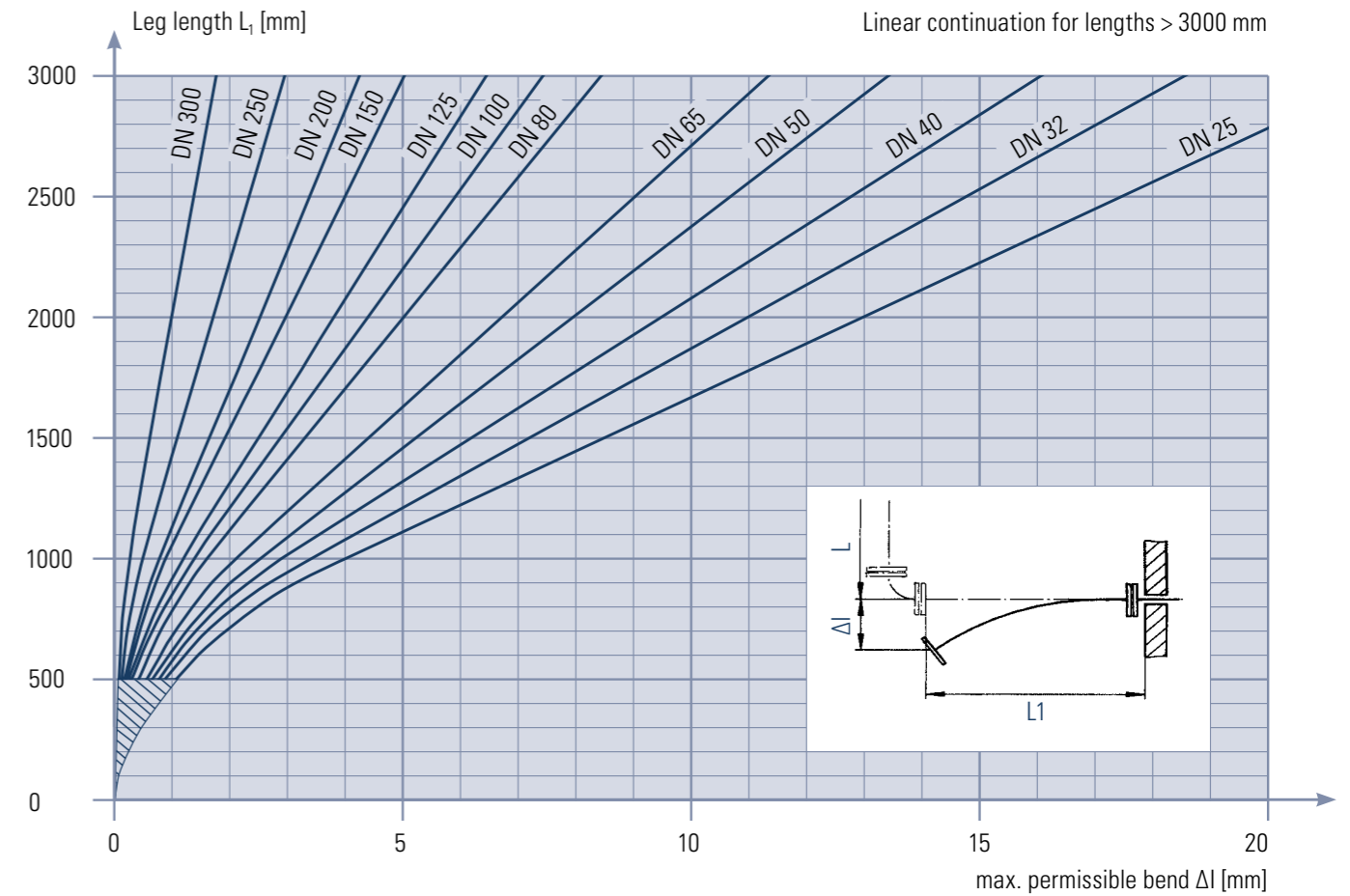

Example:

A glass lined steel pipeline DN 25 with $L = 6,5$ m is used in a temperature range from -10 °C to $+130$ °C.

From the table "Expansion of glass lined pipes in length" you get the following value: $t_2 - t_1 = 130 - (-10) = 140$ °C the value = $1.68 \frac{\text{mm}}{\text{m}}$

Therefore the value: $\Delta l = 1.68 \frac{\text{mm}}{\text{m}} \cdot 6.5\text{m} \approx 11$ mm.

The "admissible bending of glass lined pipes" diagram shows that the longitudinal expansion can be taken up by a pipe leg set at a right angle with $L_1 \geq 1800$ mm. A compensator will be required if this is not the case.

GLASS LINING TECHNOLOGIES

JOBGING FOUNDRY

FITTINGS AND VALVES

DRAINAGE TECHNOLOGY

ENGINEERING

Düker GmbH & Co. KGaA

Hauptstraße 39-41
D-63846 Laufach

Phone +49 6093 87-0
Fax +49 6093 87-246

Internet: www.dueker.de
E-Mail: info@dueker.de